

Adjustable feet 01

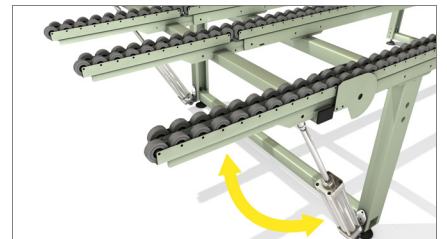

Tilting roller conveyor 02

Link

Roller table for frames transfer

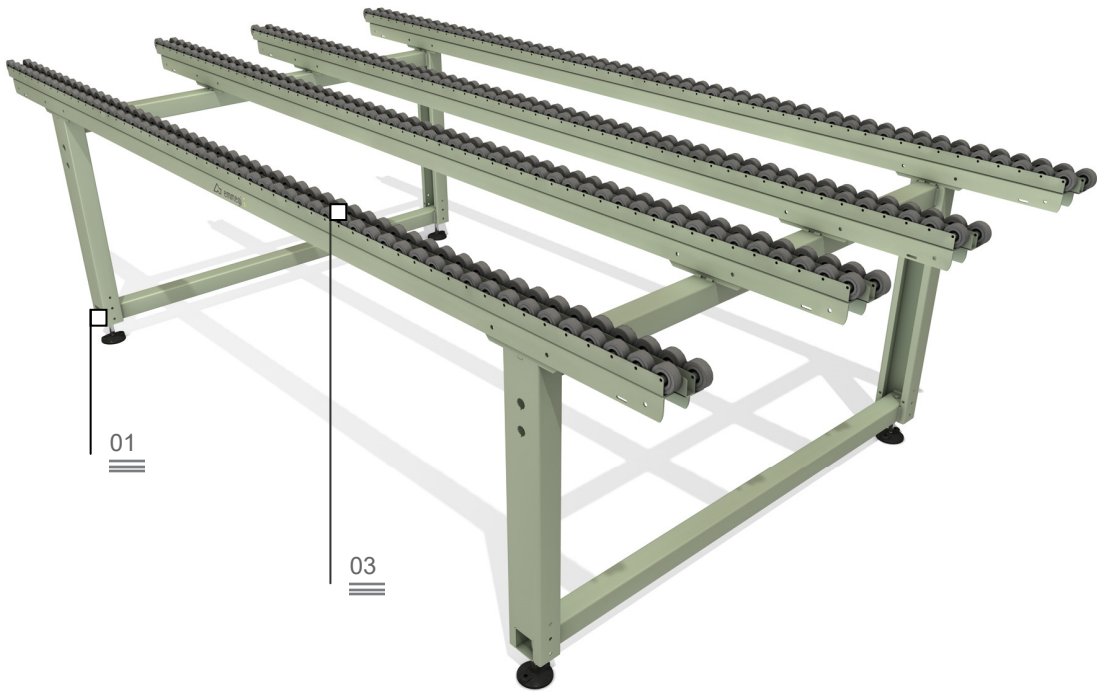

Designing the correct flow of materials, whether intermediate products, parts in the assembly phase or finished products, plays an important role in rationalising and optimising the production cycle. The Emmegi Logistics Line provides window manufacturers with a concrete solution for their storage, handling and assembly needs.

Link is a roller table that makes it possible to link assembly stations and transfer even extremely heavy frames with the utmost ease.

Roller table 03

Surface in soft nonslip PVC 04

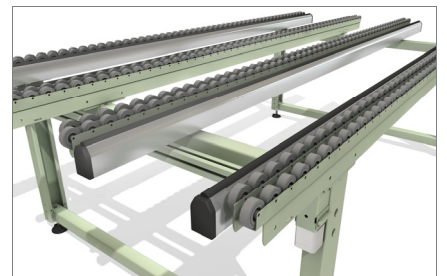
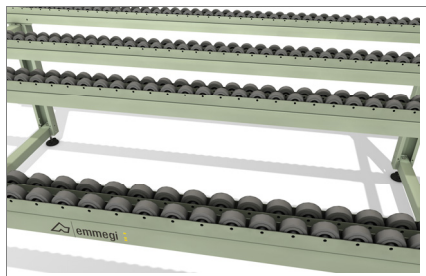
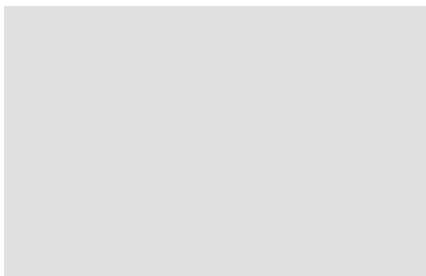

Link

Roller table for frames transfer

01 Adjustable feet

Height adjustable feet to ensure the worktable can be positioned at the required height and perfectly flush with the other products in the Dynamic Line. The feet also have holes so they can be anchored to the floor.

02 Tilting roller conveyor

The surface is composed of rows of rollers faced in soft PVC; the two ends of the roller conveyor on the right and left can be tilted by means of pneumatic cylinders (optional).

03 Roller table

The support surface is formed of a large number of rollers with anti-scratch rubber facing to ensure high speed handling of the frame.

04 Surface in soft nonslip PVC

The machine can be optionally equipped with a soft PVC support surface. The soft PVC support surface provides a high friction coefficient, which is a valuable asset during assembly procedures.

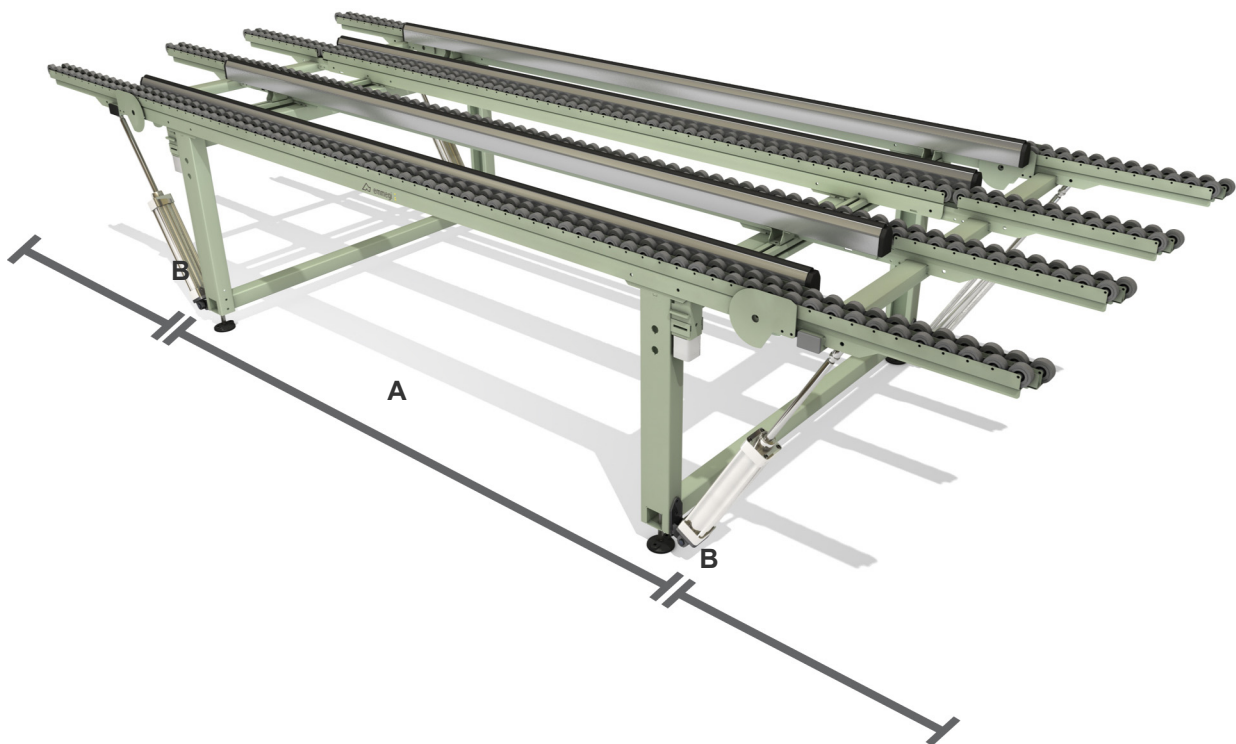

TECHNICAL CHARACTERISTICS

Length (depending on model) (mm) - A	1.400 2.000 2.500 3.000
Width (depending on model) (mm)	1.400 1.600
Max load on tilting roller conveyor (kg)	250
Number of rows of rollers installed (depending on width: 1,400 / 1,600)	3 / 4
Tilting roller conveyor length (mm) - B	594
LH tilting roller conveyor	<input type="radio"/>
RH tilting roller conveyor	<input type="radio"/>
Roller table	<input type="radio"/>
Air consumption (NI/cycle)	26